

CITY OF WINNEMUCCA
PUBLIC WORKS MANUAL

SECTION "D"
WATER SYSTEM IMPROVEMENTS

CITY OF WINNEMUCCA PUBLIC WORKS MANUAL
SECTION D: WATER SYSTEM IMPROVEMENTS

General Notes:

1) All construction shall be in conformance with the latest edition of the “**Standard Specifications for Public Works Construction**” (commonly referred to as the “orange book”), and the “**Standard Details for Public Works Construction**” as published by Washoe County RTC ... unless specifically modified in writing by the City.

2) Listed below are some of the more common requirements/specifications used on water projects for easy reference by the public, developers and contractors:

Trench Excavation and Backfill:

Materials: Refer to Section 200.03 of the Standard Specifications.

Construction: Refer to Section 305 of the Standard Specs.

Maximum backfill lift shall be 12 inches.

Required compaction in streets: 95 %.

Concrete Slurry required on all collector streets (see Section 202.02).

Water Pipe:

Materials: Refer to Section 203 of the Standard Specs:

PVC: C-900 Class 150 (minimum 8-inch diameter).

Construction: Refer to Section 307 of the Standard Specs:

Bury Depth shall be four feet to top of pipe in developed streets and five feet in undeveloped areas.

Sand pipe bedding may be required by the City Engineer where native material is unsatisfactory. Trench backfill must be compacted to 95% of maximum dry density. All trenches shall satisfy current OSHA standards.

Fire Hydrants:

Materials: Refer to Section 217 of the Standard Specs:

Construction: Refer to the Standard Detail.

Water Valves and Fittings:

Materials: All connections shall be mechanical joint type. Valves shall have two inch square operating nut.

Construction: Refer to Standard Detail.

OTHER WATER REQUIREMENTS AND NOTES:

- 1) The minimum water main pipe size is eight inch diameter.
- 2) Water main depth shall be four feet to top of pipe in developed streets and five feet to top of pipe in undeveloped areas.
- 3) Water mains shall be installed in street right-of-ways or dedicated utility easements.
- 4) Water valves shall be installed at all intersections and where designated by the City Engineer.
- 5) Fire hydrant spacing will be a minimum of 500 feet in residential areas, 250 feet in commercial/industrial areas and where designated by the City Fire Chief.
- 6) A credit for water connection fees will be applied to new structures built on vacant lots if the property has had a structure serviced by the City Water System within the last five years of the time the new building permit is issued. To be eligible for a credit, the Building Department must have written record of the demolition of the structure and the number of water connections removed when the structure was demolished or removed. The credit will be applied to the building permit issued for the new structure. Any property that has stood vacant longer than five years must pay the CURRENT demand charges for water connections when a building permit is obtained and will not receive credits for previous connections paid at a lesser rate unless specifically authorized by the City Council.
- 7) Water and sewer mains that are installed parallel to each other must be installed a minimum of ten (10) feet apart (horizontally). When a sewer and water main cross with less than 18 (eighteen) inches separation (vertically) the water main shall be encased in 2 (two) inches of concrete 10 (ten) feet on each side of the sewer main.
- 8) All water mains shall be designed by a professional engineer licensed by the State of Nevada and approved by the City Engineer.
- 9) Water mains shall be pressure tested at 150 psi for a minimum of four hours with acceptable pressure losses found in the Standard Specifications.
- 10) Water mains shall be chlorinated as required in the Standard Specifications.
- 11) The transfer of water units from one parcel to another is prohibited unless unusual circumstances exist and the City Council approves the transfer (see Resolution 93-2).
- 12) The City Water Ordinance provides for cost reimbursements to developers that extend sewer mains provided that certain conditions are met (WMC 13.08.240).

WATER SERVICE POLICY

- 1) The City will install a complete service for its standard fee (as listed in the Water Ordinance). This includes a service saddle, corp stop, PE service line, curb stop, meter yoke, water meter and complete box installed near the property line. The City will not perform work on private property.
- 2) A water service shall IN NO CASE cross through one parcel to serve another parcel (regardless of ownership) without a recorded easement acceptable to the City. A separate water meter will be required for each home (exception - mobile home parks). All services shall be constructed perpendicular to the water main.
- 3) All water service lines shall enter and exit the meter boxes at a minimum depth of 30 (thirty) inches. The meter shall be installed at a depth of between 18 (eighteen) and 24 (twenty four) inches (top of meter to top of box lid).
- 4) Service stub on customer side of meter yoke shall be constructed of class one hundred fifty (150) PVC pipe of equal size (to a point outside of meter box). All meter boxes shall be located in the sidewalk area with the top of lid matching the sidewalk elevation (existing or future sidewalk).

The standard water service material will be as follows unless an approved equal is allowed by the City.

Single 1" Service:

SERVICE SADDLE 6" OR 8": Single stainless steel strap: Romac 202N
METER BOX: Christy B-16
METER BOX EXTENSIONS: Christy B-16 x 12"
METER BOX LID: Christy B-16G
CORP STOP: Ford F-500
MALE x 1" PACK JOINT
FEMALE x 1" PACK JOINT
1" METER YOKE: Ford Y-504 - 502
YOKE VALVE
YOKE ELBOW
YOKE EXPANSION JOINT
1" SERVICE PIPE: 200# CTS Polyethylene
1" METER: Sensus or Badger

Single 2" Service:

SERVICE SADDLE 6" or 8": Single stainless steel strap: Romac 202N
METER BOX: Christy B-36
METER BOX EXTENSIONS: Christy B-36 x 12"
METER BOX LID: Christy B-36G
CORP STOP:
MALE x 2" PACK JOINT
FEMALE x 2" PACK JOINT
2" METER SET W/DIYBKE CHECK VALVE & BYPASS
2" SERVICE PIPE: 200# CTS Polyethylene
2" METER: Sensus or Badger

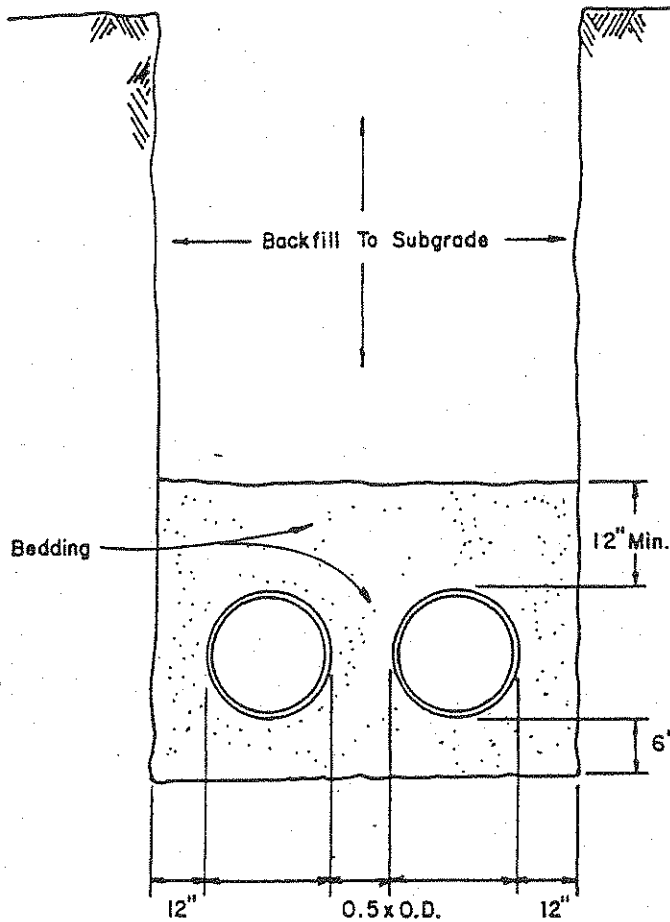
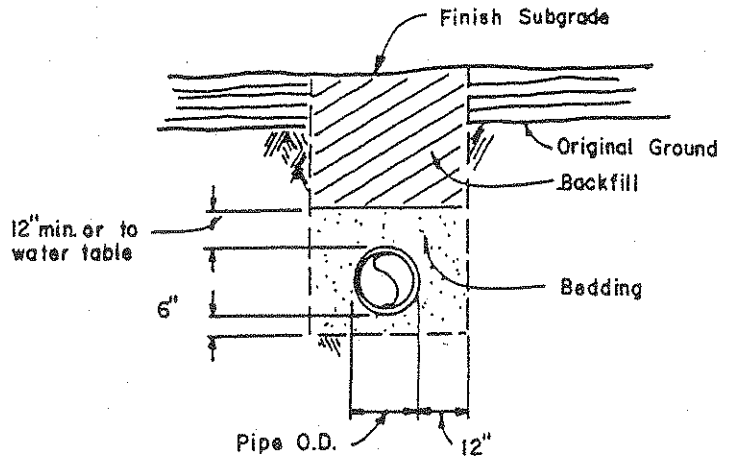
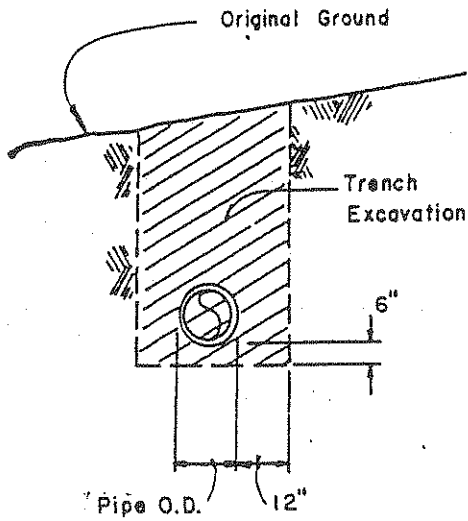

GENERAL NOTES:

- 1.) Water densified backfill and tunneling shall be by special provision only.
- 2.) Backfill shall meet the requirements for Class "E" backfill with no rocks over 4" compacted in 6" (max.) lifts to min. 90% of max. dry density.
- 3.) Bedding Material shall meet requirements for Class "A" Backfill as shown in subsection 200.03.02 of Standard Specifications or as specified by the Agency and shall be compacted to at least 95% of max. dry density.
- 4.) For trenches in roadway section, see trench patch details See Dwg. No. 1-16
- 5.) For the purpose of payment, excavation and backfill quantities are based on these standard drawings, and no additional compensation will be made. Shoring or sloped cut slopes may be necessary, but there will be no additional payment. All excavations shall conform to the latest O.S.H.A. - requirements.
- 6.) Not for use in City of Reno. Refer to Dwg. R-24.
- 7.) Place metallic location tape 1 ft. above water pipe, Carson City.

NO. REVISION DATE			STANDARD DETAILS FOR PUBLIC WORKS CONSTRUCTION		SECTION			
1	Note 6	6-95	<h1>TRENCH EXCAVATION AND BACKFILL</h1>			2		
						DRAWING NO.		2-1 (305)
						DATE		7-81
						PAGE		1

WASHOE CO.: MIN 5' OR
 MIN 6' WHERE 5' W CONC SIDEWALK
 EXISTS/IS TO BE CONST
 RENO: MAX 5'

MUELLER A-442 W/5 1/4" VALVE OPENING OR
 APPROVED EQUAL, WATEROUS "PACER" WB67DDP
 OR APPROVED EQUAL IN WASHOE CO., WINNEMUCCA,
 SPARKS. NOT FOR USE IN ELKO (SHT'S E-7,E-8).

TO BE USED IN WASHOE CO. ONLY,
 WHERE SIDEWALK DOES NOT EXIST.

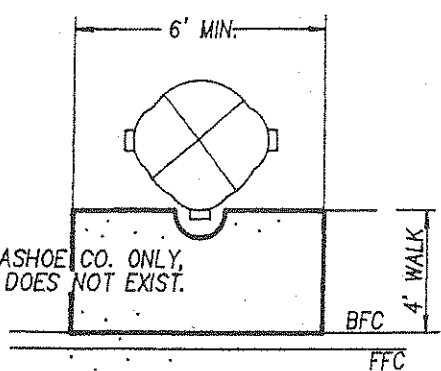

PLAN

NOTE: REINFORCING SHALL BE
 FIBERMESH, CONC SHALL BE MIN
 6.25sock 4000psi W/4.5-7.5% AIR.

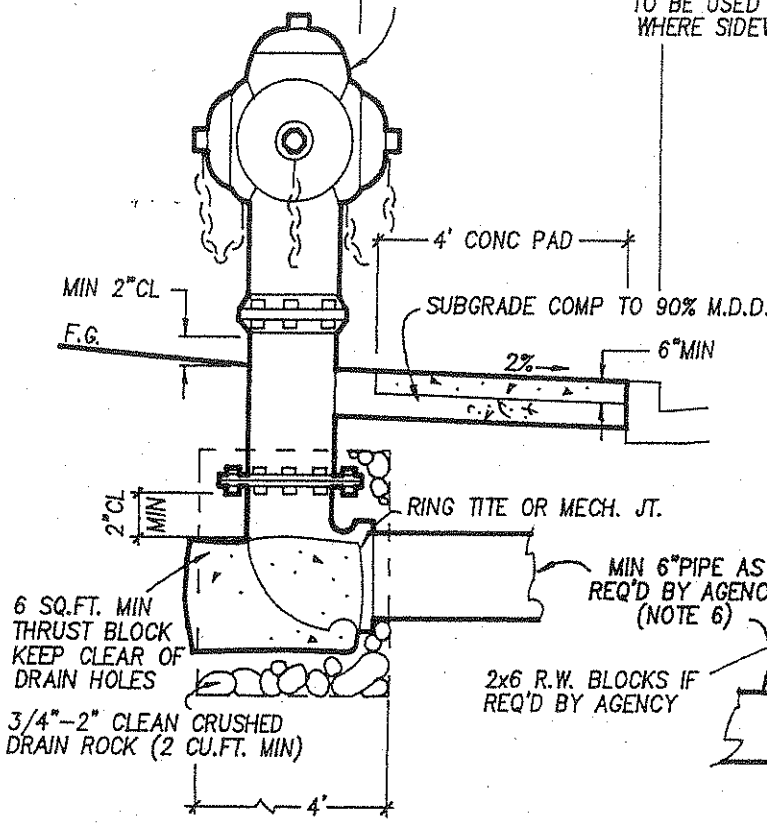

ELEVATION
 N.T.S.

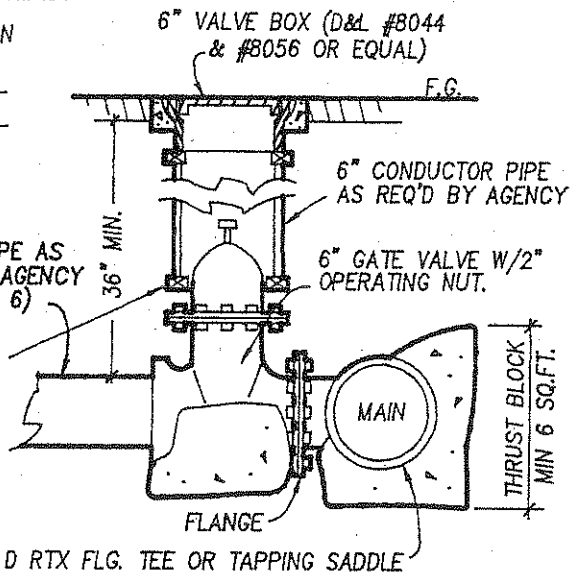

DETAIL

NOTES

1. HYDRANT SHALL BE ENAMELED RED EXCEPT IN SPARKS, WASHOE CO., YERINGTON & DOUGLAS CO. WHERE IT SHALL BE YELLOW.
2. ALL HYDRANTS SHALL HAVE (2) 2 1/2" HOSE NOZZLES & (1) 4 1/2" STEAMER NOZZLE. ALL THREADS SHALL BE AS SPECIFIED FOR AMERICAN NATIONAL HOSE COUPLING EXCEPT RENO, SPARKS & WASHOE CO. (DET. "A")
3. OPERATING NUT SHALL BE 1 1/2" PENTAGON EXCEPT: RENO, SPARKS AND WASHOE CO. (DET. "B")
4. INSPECTION BY APPROPRIATE AGENCY SHALL BE REQUIRED PRIOR TO BACKFILLING.
5. YERINGTON MIN. DEPTH OF MAIN SHALL BE 42".
6. LANDER CO. - BUTTERFLY VALVE SHALL BE USED IN LIEU OF GATE VALVE IN STREET. WATER PIPE SHALL BE PVC CLASS 150. NO A.C. IN WASHOE CO.
7. NO FENCES SHALL BE ALLOWED WITHIN 3' OF ANY PORTION OF A FIRE HYDRANT.
8. IN CARSON CITY, SEE DET. "C-10.3"

NO.			REVISION			DATE			STANDARD DETAILS FOR PUBLIC WORKS CONSTRUCTION			SECTIONS		
RED			AWN			11/94vp			FIRE HYDRANT			3		
												DRAWING NO. 3-1.1 (307)		
												DATE 11/94 vp PAGE 1		

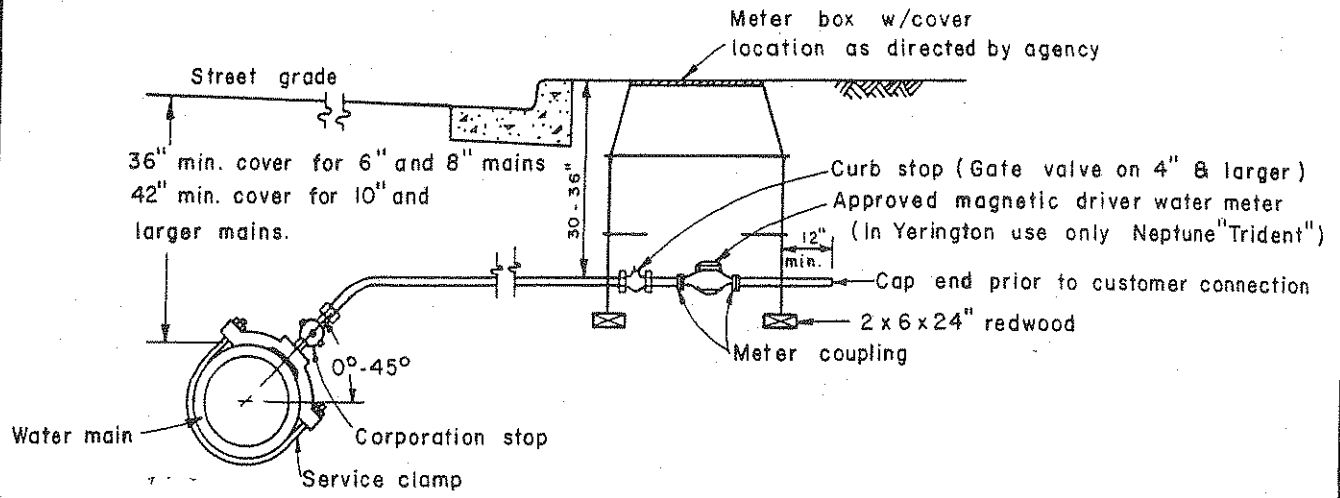

ALTERNATE "A"

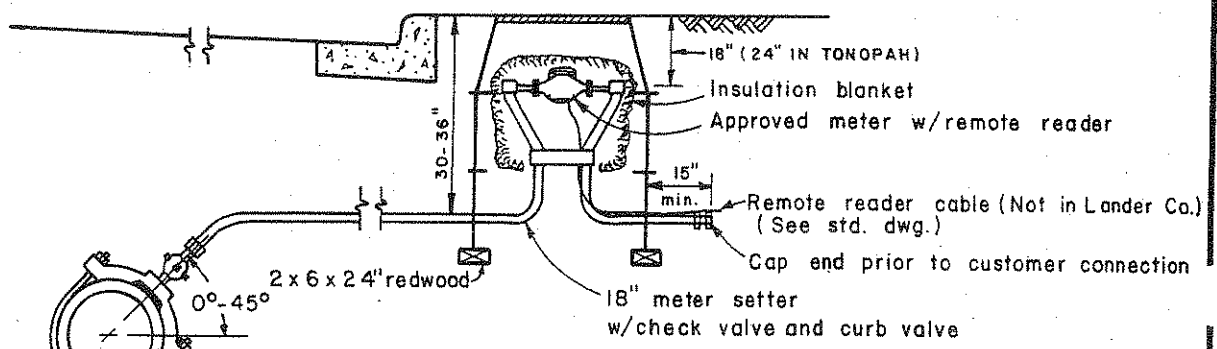

ALTERNATE "B"

NOTE:

1. Not for use in Carson City.
2. Water meters shall be installed where required. Where meters are to be installed by others or at later date, an idler shall be installed.
3. Water service connections shall be as shown for non-meter applications.
4. Corporation stop, curb stop and service line shall be of the same size.
5. Flared type couplings shall be used at all connections.
6. Meter assembly, consisting of curb stop, meter couplings and meters shall be centered in meter box.
7. Alternate Type "A" or "B" to be determined by governing agency.

NO. REVISION DATE			STANDARD DETAILS FOR PUBLIC WORKS CONSTRUCTION		SECTION	
1	NOTE 1-7	10-85	WATER SERVICE CONNECTION W/METER		3	
					DRAWING NO. 3-4.2 (307)	
					DATE 7-81	PAGE 6

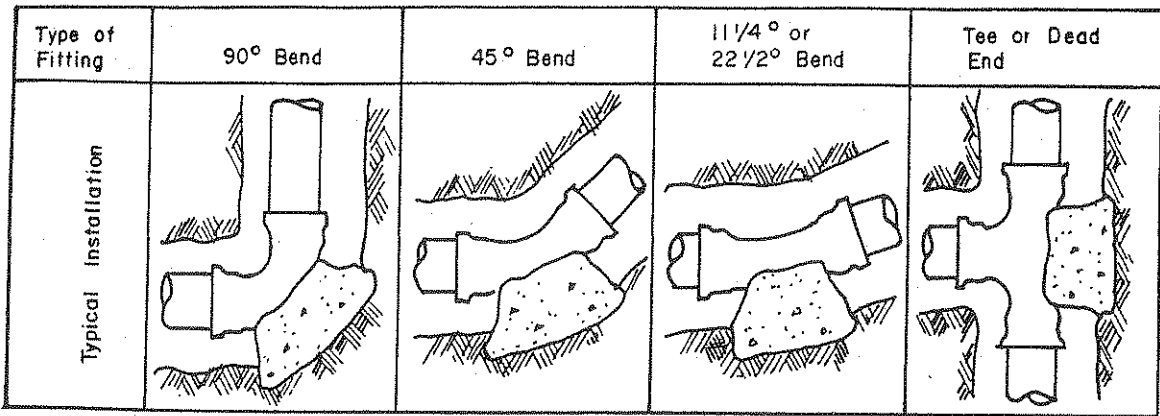

THRUST BLOCK BEARING AREA (sq. ft.)

Type of Fitting	90° Bend	45° Bend	1 1/4° or 22 1/2° Bend	Tee or Dead End	Tee w/plug	Cross w/plug
4"	2	1	1	2	2	2
6"	4	4	2	4	4	4
8"	7	4	2	5	7	7
10"	12	6	3	8	12	12
12"	16	10	5	12	16	16
14"	20	12	6	14	20	20
16"	27	15	8	18	27	27
18"	45	25	13	32	45	45
24"	65	35	18	46	65	65

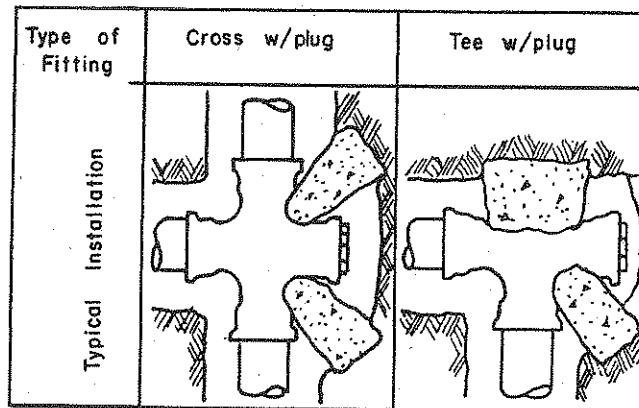

NOTES:

- 1) Thrust blocks to be constructed of class "C" concrete.
- 2) Areas given are for class 150 pipe at test pressure of 150 P.S.I., with 2000 P.S.F. bearing capacity. Installations using different pipe, test pressures, and/or soil types should adjust areas accordingly, subject to approval of engineer.
- 3) Blocks to be poured against undisturbed soil.
- 4) Joints and face of plugs to be kept clear of concrete.

NO.	REVISION	DATE	STANDARD DETAILS FOR PUBLIC WORKS CONSTRUCTION	SECTION
1	NOTE 2	3/83	THRUST BLOCK BEARING AREAS	3
				DRAWING NO. 3 - 7 (307)
				DATE 7 - 81

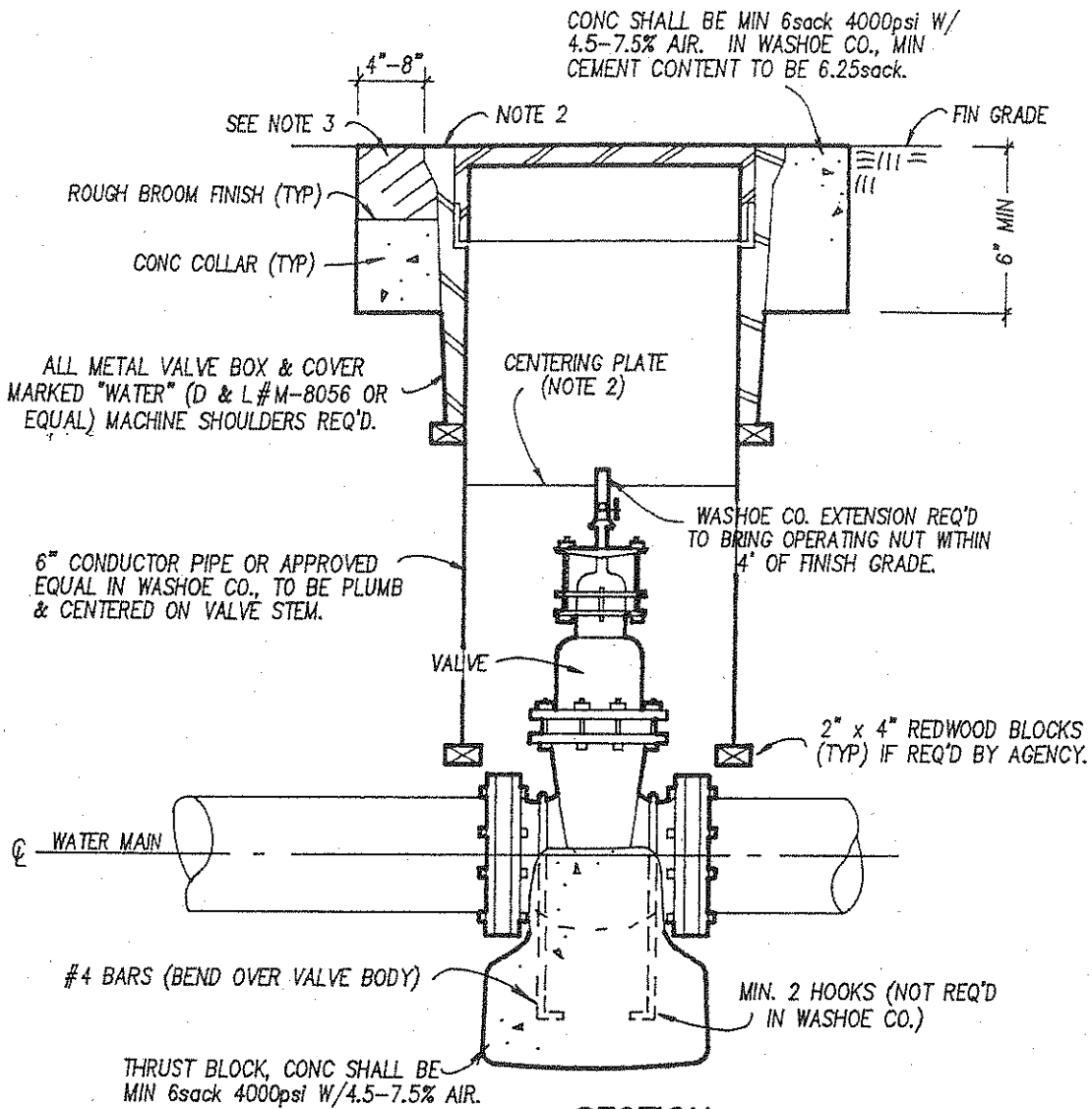

SECTION
N.T.S.

NOTES

1. SEE DWG 3-7 FOR THRUST BLOCK SIZE.
2. IN WASHOE CO., VALVE BOXES FOR BOTH GAS & WATER TO BE SET 3/8"-5/8" BELOW FINISH ROADWAY SURFACE. INSTALL OPERATING EXTENSION W/OPERATING NUT RESTRAINING BOLT & TOP CENTERING PLATE. ANCHOR BARS & REDWOOD BLOCKS NOT REQ'D WHEN OPERATING NUT IS AT GREATER DEPTH THAN 4' FROM FIN GRADE.
3. IN WASHOE CO., CONC COLLAR TO BE LEFT 2" BELOW FINISH ASPH SURFACE. PLACE 2" OF TYPE 3 ASPH PAVING AROUND VALVE BOX. APPLY SS-1 TACK COAT BEFORE PAVING. SEAL A.C. SURFACE W/SS-1 SAND. CHIP SEAL, FOG SEAL, SAND SEAL OR SLURRY SEAL PAVED SURFACE AS REQ'D BY PLANS OR SPECS. EXTEND CONC COLLAR TO GRADE WHEN NOT LOCATED IN ASPH PAVE OR IN UNPAVED AREA.
4. IN CARSON CITY REFER TO DETAIL C-10.1
5. RENO ONLY: PLACE VALVE BOX & CONC COLLAR FLUSH W/ASPHALT.

NO.	REVISION	DATE	STANDARD DETAILS FOR PUBLIC WORKS CONSTRUCTION	SECTIONS
1	REDRAW	3/94vp	VALVE, BOX & COVER	3
2	NOTES 2,3,4	1/95vp		DRAWING NO. 3-9 (307)
3	NOTE 5	4/95vp		DATE 7/90 PAGE 11